

# The Swallow

## Fume Extraction System for Lasers

### The Swallow 4000 Filtered Fume Extraction for Lasers

The Swallow is an air cleaner designed for the removal of particulates and gaseous contaminants and is typically suspended above the laser process workspace.

It is designed specifically for applications that include areas having high load particulate concentrations such as laser welding where direct source capture may be difficult. Laser fume absorbent canisters are also an optional stage of filtration to control odors and gases.

The 4000cfm unit (6800m<sup>3</sup>/hr) accepts multiple stages of air filtration where the user can select from a variety of particulate or gaseous/chemical filtration depending on the laser process.

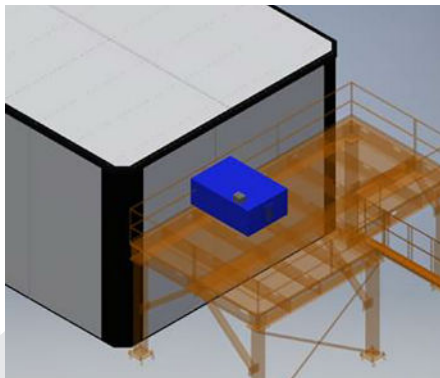

Typical Installation of Fume Extraction System with Laser Castle laser safety cabin

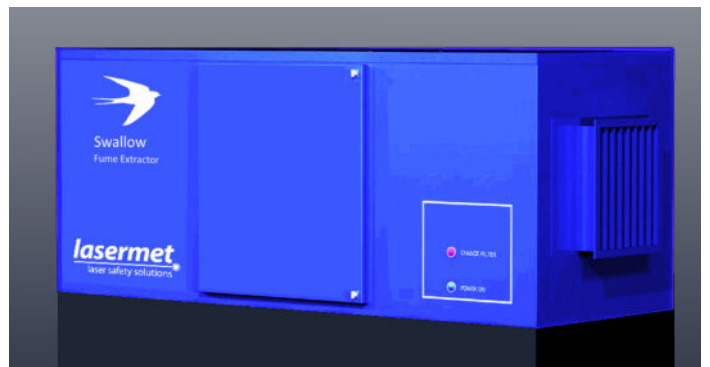
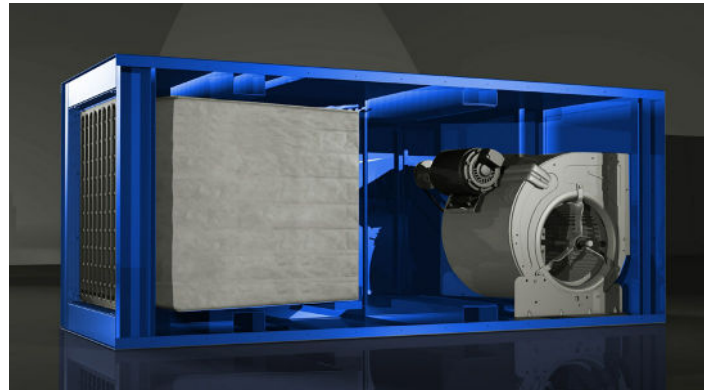

The Swallow 4000 Fume Extraction System for Lasers  
Model No. FES-SW-4000

1. A full size air intake draws contaminants and recirculates filtered air
2. Internal air filters are sealed with full gaskets
3. Filter options include: pre-filtration, a secondary filter, HEPA or absorbent filters
4. 4000cfm (6800m<sup>3</sup>/hr) unit
5. Directional louvers adjustable for returned air
6. LED indicators for filter pressure drop and unit operation.
7. Service door provides access to all components
8. Power options: 120VAC-1Ph, 230VAC-3Ph, 480VAC-3Ph

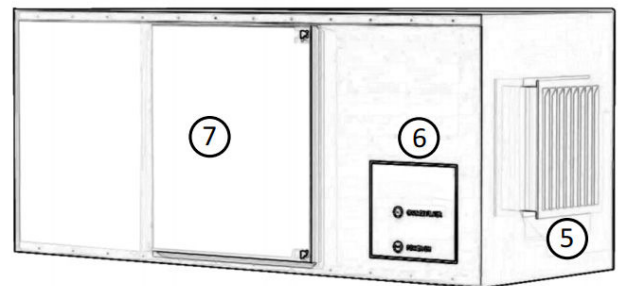
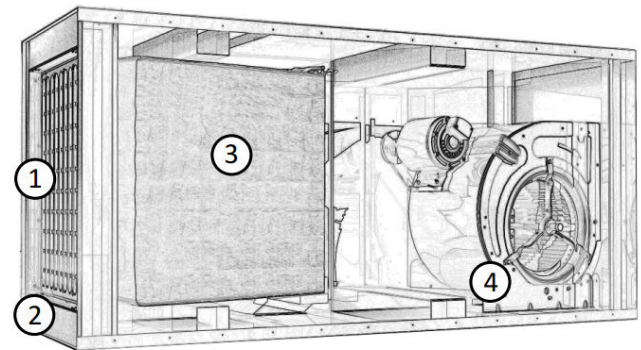

**lasermet**  
laser safety solutions\*

# The Swallow

## Fume Extraction System for Lasers

### System Description

The air cleaner is a self-contained unit with a fan, a pre-filter section, final filter section, (a HEPA filter section,) and LED indicator lights to identify power on and filter change time.

The unit enclosure is constructed from 16-gauge powder coated steel. The pre-filter and final filter access is from the air intake end of the unit and includes an integral filter holding frame that enables filters to be installed without using the fasteners.

The unit accomodates a 50mm or 100mm pre-filter. The second stage accomodates a specific HVAC air filter. The third stage includes a HEPA filter holding frame for the HEPA air filter.

The fan is positioned at the air exit side of the unit and has a rated capacity of up to 4000cfm (6800m<sup>3</sup>/hr) with air filters installed.

An air supply register with adjustable directional louvers is built into the air exit side of the unit.

### Typical Air-Changes per Hour

Lasermet's standard cabin measures 8 x 5 x 3.5m which is 140m<sup>3</sup>.

For this size of cabin the Swallow Fume Extraction System will provide 50 air-changes per hour.

### Main Features

The unit has a **full size air intake** that draws fumes and other contaminants from the room. This air is then filtered through each stage and re-circulated back into the conditioned space.

**Internal air filter holding assemblies include gaskets** which prevent air bypass and ensure that all of the air is being treated by the system. Primary and secondary air filters are installed from this end of the unit. Installation of replacement filters does not require tools or fasteners.

**Filter Options:** Air filters can be selected specific to the volume and type of contaminant concerned. The options include pre-filtration, a secondary or final filter, and/or a HEPA or absorbent filter(s) at the final stage.

The **4000cfm (6800m<sup>3</sup>/hr)** rated unit has a fan that provides a uniform airflow at sustainable noise levels.

**Adjustable directional louvers** return the filtered air into the working space.

**LED lights show when the unit is ON** and the particulate air filter pressure drop (and unit operation).

### Power Supply Options and Ordering Data

Power Supply	Part No.
120VAC 1-Phase	FES-SW-4000-120-1
230VAC 3-Phase	FES-SW-4000-230-3
480VAC 3-Phase	FES-SW-4000-480-3

### Specifications: Swallow 4000

Dimensional and Performance Data	Part No. FES-SW-4000
Rated Airflow	4000cfm (6800m <sup>3</sup> /hr)
Air-changes per hour for 140m <sup>3</sup> cabin	50 Air-changes per hour
Pre-filter	Option
Final Filter	HEPA or Absorbent Filter
Canisters	Option
Sound Level @ 5ft Perimeter	73dB
Operating Weight	226.8kg
Width	1.4m
Depth	0.8m
Height	1.9m
Voltage	120VAC 1-Ph 230VAC 3-Ph 480VAC 3-Ph
Power Consumption	1030W
Throw (Distance @ 100fpm)	30.5m

